

Capacities/Dimensions

Snow Tank

| | | |
|---------------|---------------------|-------------------|
| Actual Volume | 2.83 m ³ | (100 cu. ft.) |
| Compacted | 3.54 m ³ | (125 cu. ft.) |
| Excess Water | 416 L | (110 USG, 92 IMP) |

Water

| | | |
|------------|--------|--------------------|
| Ice Making | 738 L | (195 USG, 162 IMP) |
| Wash Water | 310 L | (82 USG, 68 IMP) |
| Total | 1048 L | (277 USG, 230 IMP) |

Hydraulic Oil

| | |
|------|-------------------|
| 95 L | (25 USG, 21 IMP) |
|------|-------------------|

Conveyor System

| | | |
|-------------------|---------|---------------|
| Horizontal System | 25.4 cm | (10 in.) dia. |
| Vertical Auger | 25.4 cm | (10 in.) dia. |

Overall Length

| | | |
|----------------|--------|-----------|
| Snow Tank Down | 4.04 m | (159 in.) |
| Snow Tank Up | 5.03 m | (198 in.) |

Overall Height

| | | |
|----------------|--------|------------|
| Snow Tank Down | 2.16 m | (85 in.) |
| Snow Tank Up | 5.03 m | (154 in.) |

Overall Width

| | |
|--------|------------|
| 2.13 m | (84 in.) |
|--------|------------|

Wheelbase

| | |
|--------|-----------|
| 1.95 m | (77in.) |
|--------|-----------|

Wheel Track

| | |
|--------|------------|
| 1.37 m | (54 in.) |
|--------|------------|

Turning Radius

| | | |
|----------------|--------|------------|
| At Conditioner | 4.86 m | (16 ft.) |
|----------------|--------|------------|

Shaving Blade

| |
|--------------------------|
| 1.27 x 12.7 x 195.6 cm |
| 1/2 in. x 5 in. x 77 in. |

Vehicle Weight

| | | |
|---------|---------|------------|
| Empty | 2912 kg | (6420 lb.) |
| w/Water | 3910 kg | (8620 lb.) |

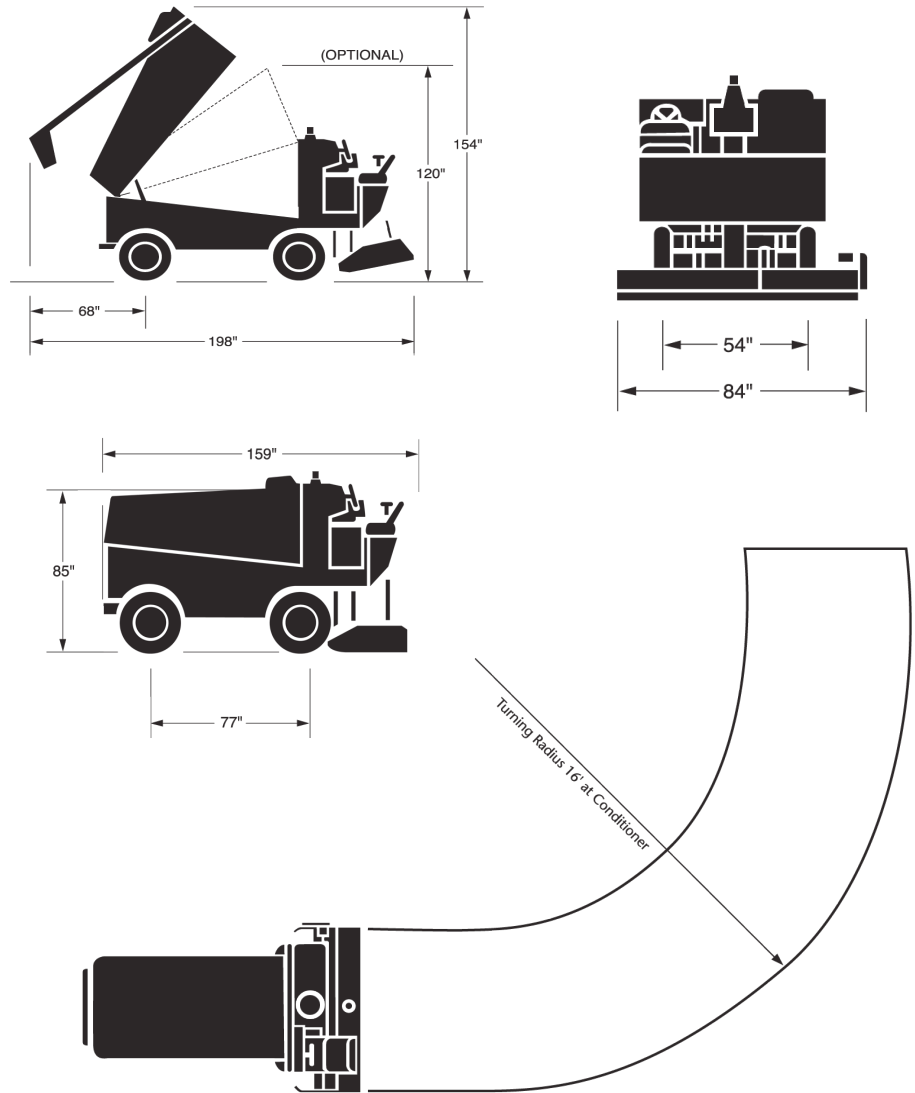

Engine Specifications/Features

Certified CARB SI Tier 3/EPA SI Tier 2 Kubota® 1.6 L engine
 Four cylinder dual overhead cam, liquid cooled, 50 HP
 Powerful and efficient.

Load sensing fuel governor enables true "hands-free" operation by driver.

This brochure has been prepared only as a general guide for the customer. Every effort has been made to assure that the information is correct at the time of its printing. Some features described or shown may be optional at extra cost and prices, colors, materials, specifications and models are subject to change. Some options are required in combination with other options. ZAMBONI and the configuration of the Zamboni® ice resurfacing machine are registered trademarks of Frank J. Zamboni & Co., Inc. ©Zamboni 2013.

ZAMBONI®

Zamboni USA

Frank J. Zamboni & Co., Inc.
 15714 Colorado Ave., Paramount, CA USA 90723-4211
 Phone (562) 633-0751 Fax (562) 633-9365

Zamboni Canada / Europe

Zamboni Company Ltd.
 38 Morton Ave. East, Box 1388, Brantford, ON Canada N3T 5T6
 Phone (519) 758-5000 Fax (519) 758-0500

www.zamboni.com

This brochure is a PDF internet version posted on our website for reference only. The Zamboni Company assumes no responsibility for its content or use. For product and sales information, please contact the Zamboni Company.

